

HG1 с редуктором из алюминия

HG1 with aluminium gear operator

DN 50 - DN 300

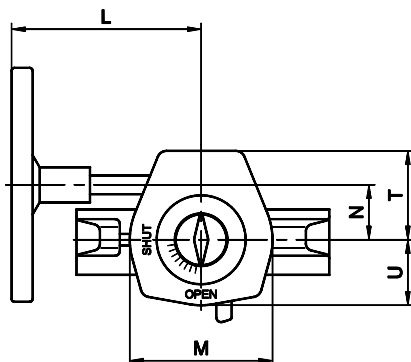
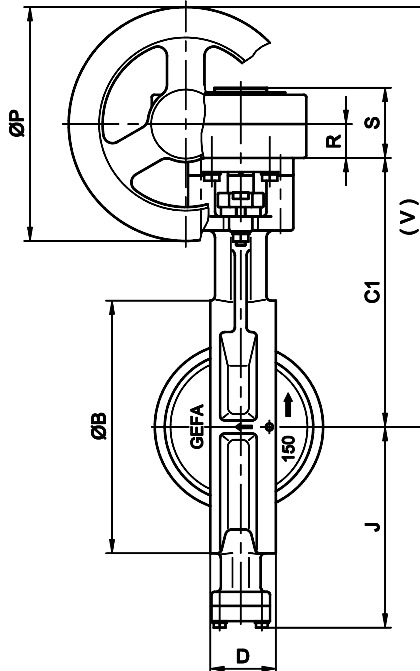
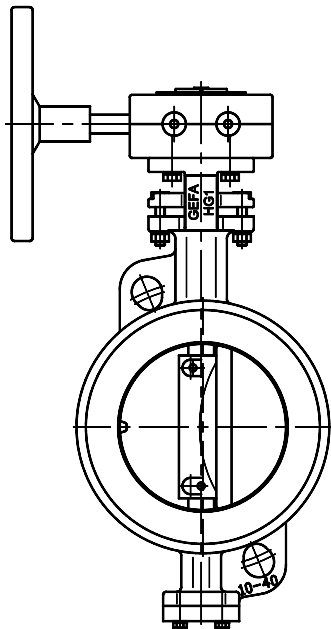

Материал редуктора / Gear materials
 Корпус / Body: алюминий / aluminium
 вал / Stem: сталь / steel
 маховик / Handwheel: сталь / steel

Указан вес с маховиком и монтажной пластиной.
 Технические данные заслонки см. в соответствующих типовых листах.
 Седло: TG= седельное кольцо -PTFE/стекловолокно / M= металлическое седельное кольцо

Weight of gear operator including handwheel and mounting plate.

Regarding valve data please refer to relevant data sheets.

Seat: TG = PTFE/glass-seat / M = metal seat

DN	NPS	Седло Seat	Тип редуктора Gear type	ØB	C1	D	J	L	M	N	ØP	R	S	T	U	V	kg
50	2"	TG/M	BGM98114	102	157	43	103	150	113	39	125	31	71	64	56	251	2,0
65	2 1/2"	TG/M	BGM98114	122	169	46	115	150	113	39	125	31	71	64	56	263	2,0
80	3"	TG/M	BGM98114	133	177	46	122	150	113	39	125	31	71	64	56	271	2,0
100	4"	TG/M	BGM98114	156	194	52	135	150	113	39	125	31	71	64	56	288	2,0
125	5"	TG/M	BGM98117	188	212	56	152	187	113	39	200	31	71	64	56	343	2,5
150	6"	TG/M	BGM98117	216	230	56	174	187	113	39	200	31	71	64	56	361	2,5
200	8"	TG/M	BGM98422	268	280	60	216	197	130	52	200	32	73	83	65	412	3,3
250	10"	TG/M	BGM98422	323	310	68	248	197	130	52	200	32	73	83	65	442	3,3
300	12"	TG/M	BGM98727	375	356	78	283	246	164	67	315	38	86	109	82	552	7,7